

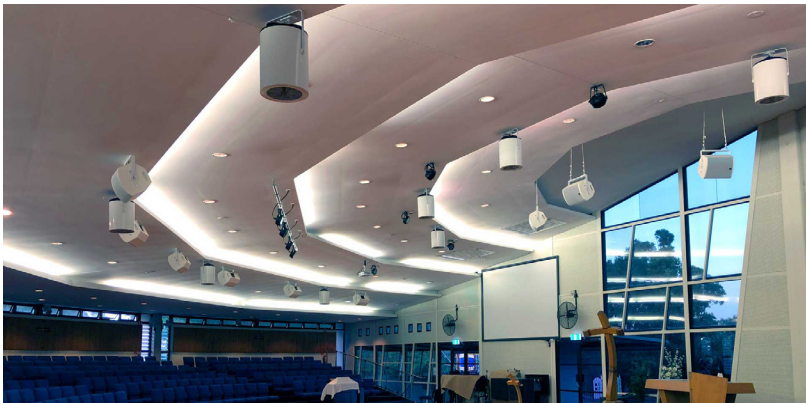

Q SERIES

Improve comfort in your facility with a system of Q Series fans



DISTRIBUTED COMFORT

Use the Q Series in high bay, sound-sensitive installations to equalize temperature and humidity in buildings that suffer from stratification. Reducing stratification increases thermal comfort during summer and winter, reduces ceiling temperature to extend the life of lighting and ceiling mounted equipment, and saves energy.

WHERE WE HELP

- › Atrium, vestibules and lobbies with overhead air supply
- › Spaces 15 ft+ or higher
- › Sound sensitive areas
- › Areas where other fans will not physically fit

Features

- › Basic permanent split capacitor or premium EC motors
- › Easy installation in new construction or retrofits
- › Unique motor mount to reduce noise and increase flow
- › 3-year parts and workmanship warranty
- › 6 ft. steel leash and anchor point for safety
- › ETL Listed in U.S. and Canada
- › 5VA Flame resistance rating
- › Made in the U.S.A.

Optional

- › Manual wall mounted control
- › Wi-Fi App based Pearlink control
- › BACnet/IP controls package for integration with existing front end control systems

Q SERIES EC

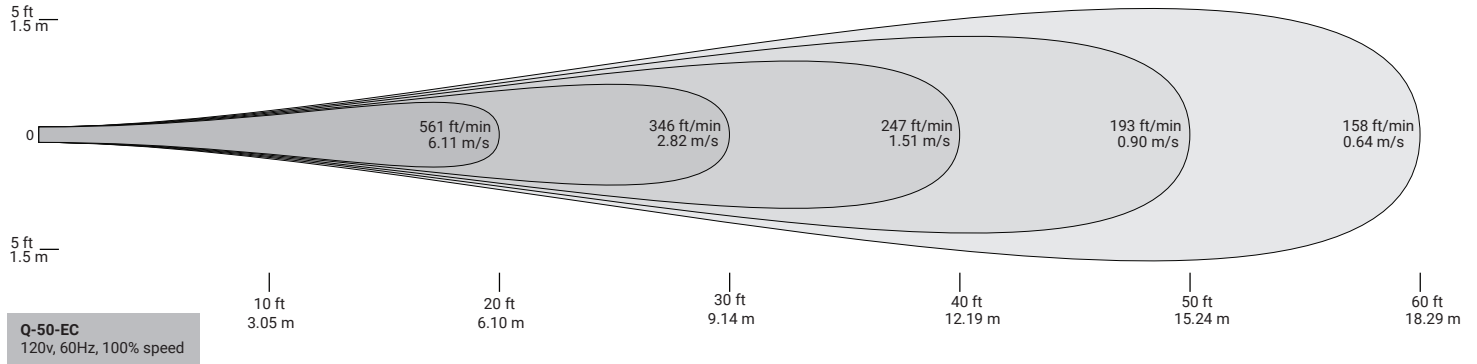

Housing: PC/ABS, UL 94 5VA flame resistance.

Motor: 300mm, electrically commutated, thermally-protected axial motor by ebm-papst®. Operating temperature: 40° F (-40° C) to 176° F (80° C). No lubrication required, bearings are sealed.

Power Cord: 6 foot cord and plug provided for 100-130V fans, no plug for 200-240V.

Control Input: 0-10VDC.

Stator: Patented multi-vane stator significantly increases air throw for maximizing performance.

Certification: Conforms to UL-507, CAN/CSA-C22.2 No. 1113. ETL listed in USA and Canada.

Safety Cable: 6' length steel cable (fastened to body)

Warranty: 3 years parts and workmanship.

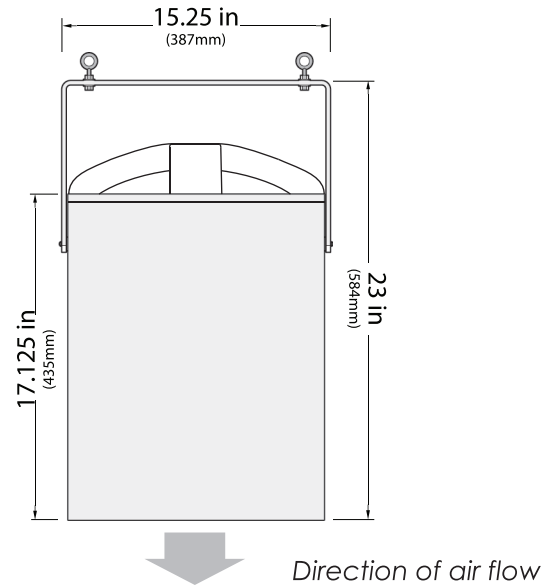

Technical Specifications



Model	Input Power, 1 Ø	Amps	Watts	RPM	dB(A) ¹	Weight	Colors
Q-50-EC-STD-100-130-X	100-130VAC, 60Hz	1.04	87	1670	41, 40, 39	22 lbs.	X = Off white (W), gray (G) or black (B)
Q-50-EC-STD-200-240-X	200-240VAC, 60Hz	0.8	98	1660	41, 40, 39	22 lbs.	X = Off white (W), gray (G) or black (B)

(1) Calculated sound pressure at 40, 45 and 50 foot distances based on non-reflective area. 73.8 dB(A) Sound Power Level, designed to meet ISO 3744 - engineering grade precision for determining sound power. Data independently verified by third party. Tests performed in-unit.

Controls & Factory Installed Options

Item	Description
Pearlink-F	Pearlink Fan Sensor- One Per Fan. Wi-Fi iOS/Android App based controller
Pearlink-T	Pearlink wired (120v) Floor Thermostat- One Per Room
POT-1	Wall-mounted speed control. Low voltage control wiring daisy-chained between fans to be controlled as a group.
BACnet	BACnet/IP package for integration with an existing BACnet system. Individually control speed, on/off and monitor fan status.

Model:	Qty:
Controls/Options:	Qty: